



Cable and wiring management for Lambretta Series III

HEADSET ROUTING FOR SERIES III CABLING

SPEEDO: This can be a right pain as it goes down the center of the forks and out the hole at the bottom. Tip here is to take the speedo inner out, turn it upside down and from the bottom feed the inner all the way up through the small hole in the forks. Now take the speedo outer and thread it over the inner, the inner cable then acts as a guide to get the outer through the small hole. Then take inner back out and fit it the correct way.

FRONT BRAKE CABLE: This comes from the lever, then loop it over so as you look at the front of the scooter it comes down the right hand side of the handle bars and horn casting. It then switches sides on the top of the forks.

GEAR CABLES: The two gear cables go down the right as you look at the front of the scooter. They then swap over to the left under the horn and go to the engine on the left.

THROTTLE CABLE: This goes down the left as you look at the front of the scooter, and swaps to the right over the bottom part of the frame.

CLUTCH CABLE: Swaps over to the other side in the headset and continues all the way down on the left (looking from the front)

NOTE: All images and information blatantly stolen from [The Rimini Lambretta Centre](http://www.rimini-lambretta.com/)

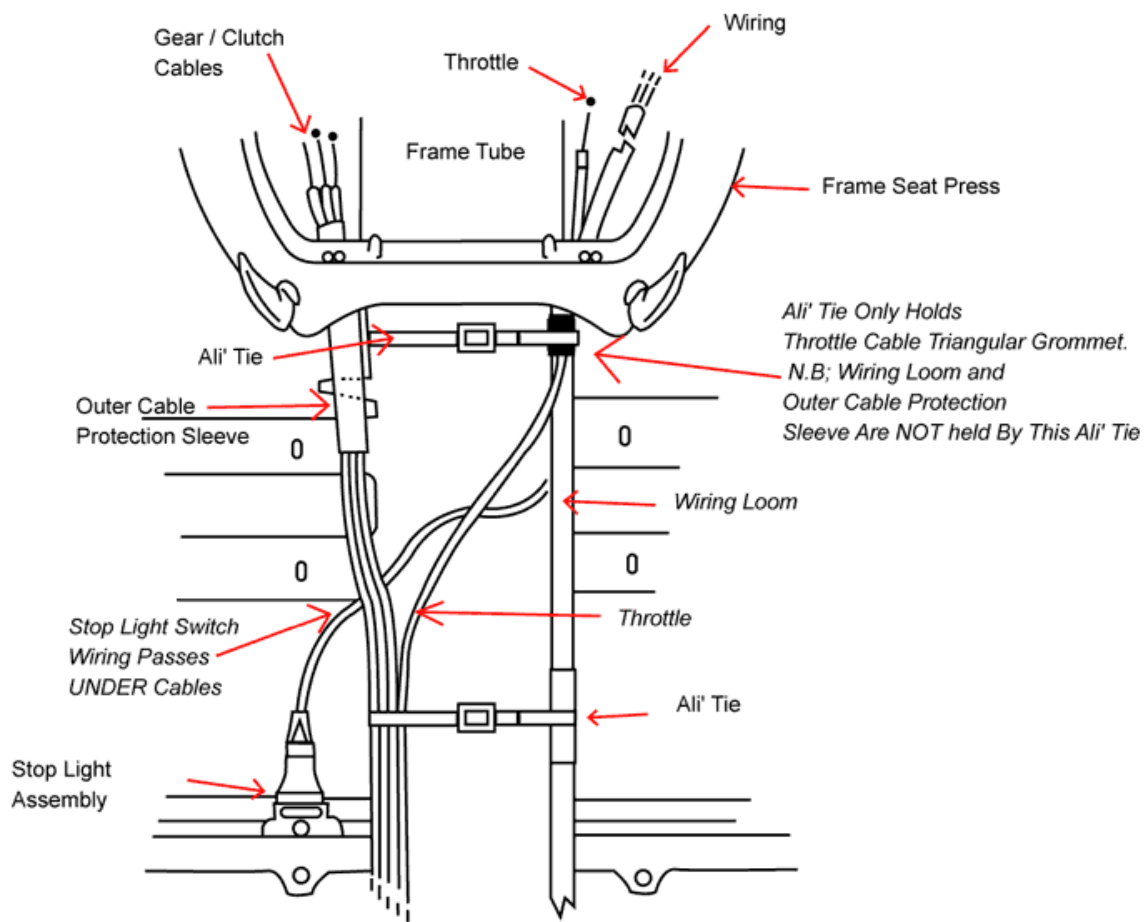

Lambretta Series III Cable Routes

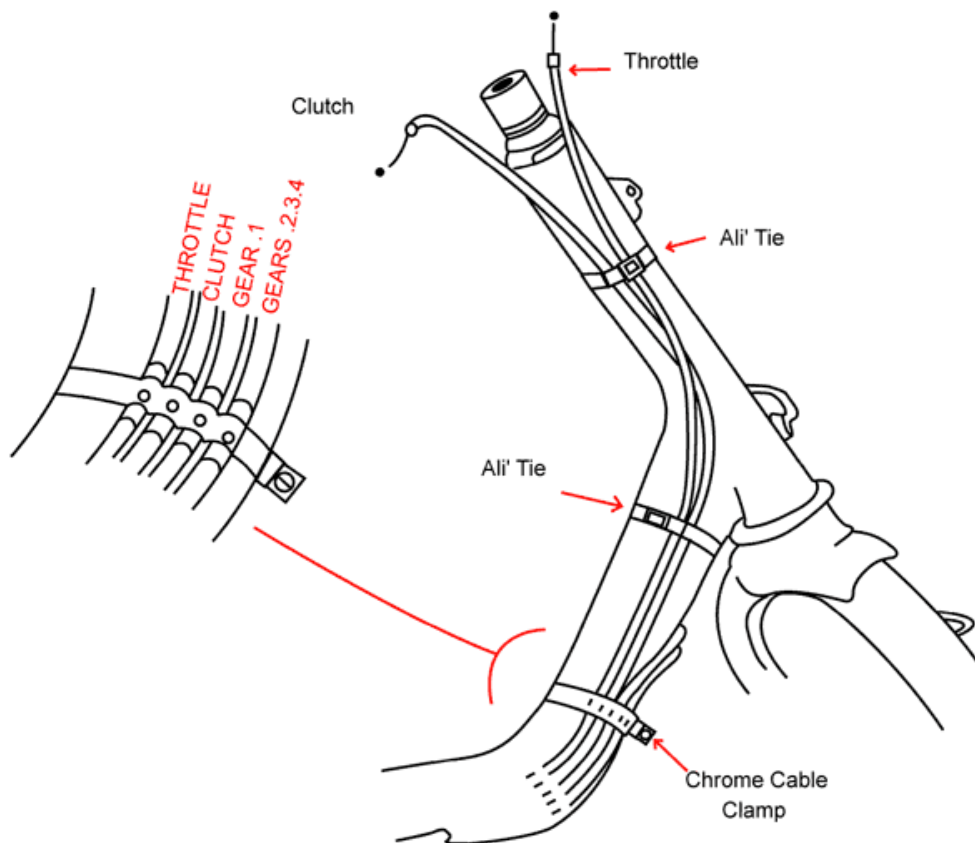

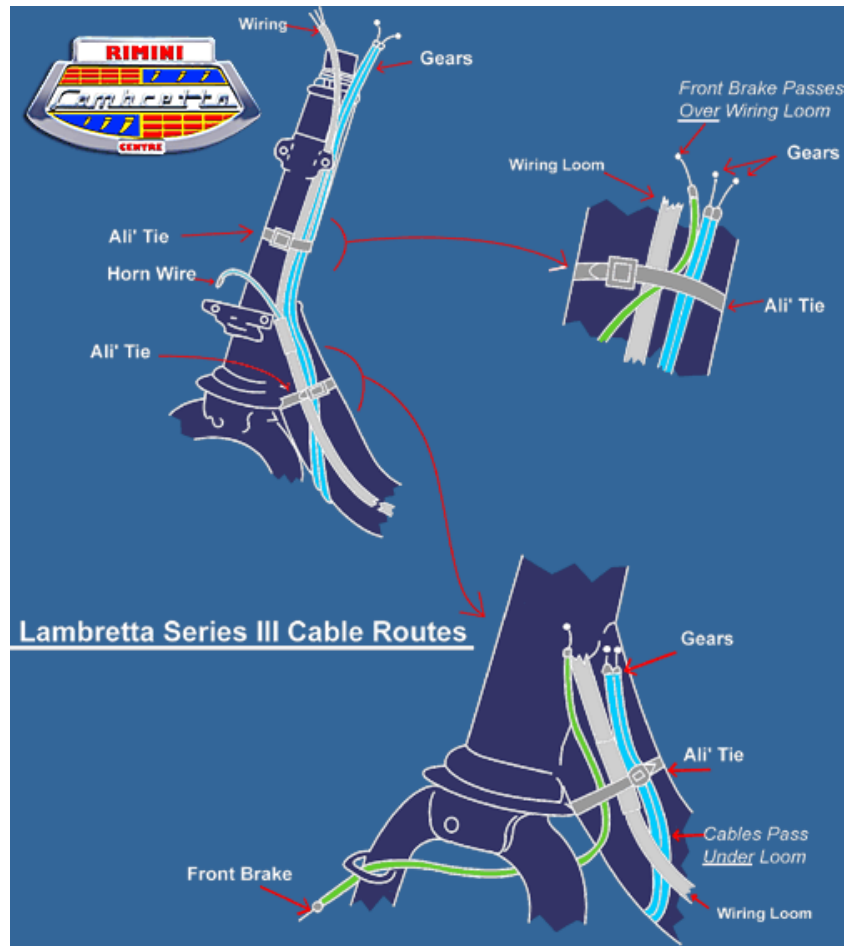

All images stolen from [The Rimini Lambretta Centre](http://www.rimini-lambretta-centre.com)



L a m b r e t t a *L a m b r e t t a* *L a m b r e t t a*
Home